

Effect of Diverse Recoding of Granule Cells on Optokinetic Response in A Cerebellar Ring Network

Sang-Yoon Kim and Woochang Lim

Institute for Computational Neuroscience and Department of Science Education, Daegu National University of Education, Daegu 42411, S. Korea

Introduction

Cerebellar Motor Learning

- Fine motor control for coordinating voluntary movements such as posture, balance, and locomotion, resulting in smooth and balanced muscular activity

Optokinetic Response (OKR)

- Eye tracks successive stripe slip with the stationary head
- Composed of two consecutive slow and fast phases (i.e., slow tracking eye-movement and fast reset saccade).

Purpose of Our Study

Investigation of Effect of Diverse Recoding of Granule Cells on Gain of OKR in A Cerebellar Ring Network by varying the connection probability p_c from the GO cell to the granule cells

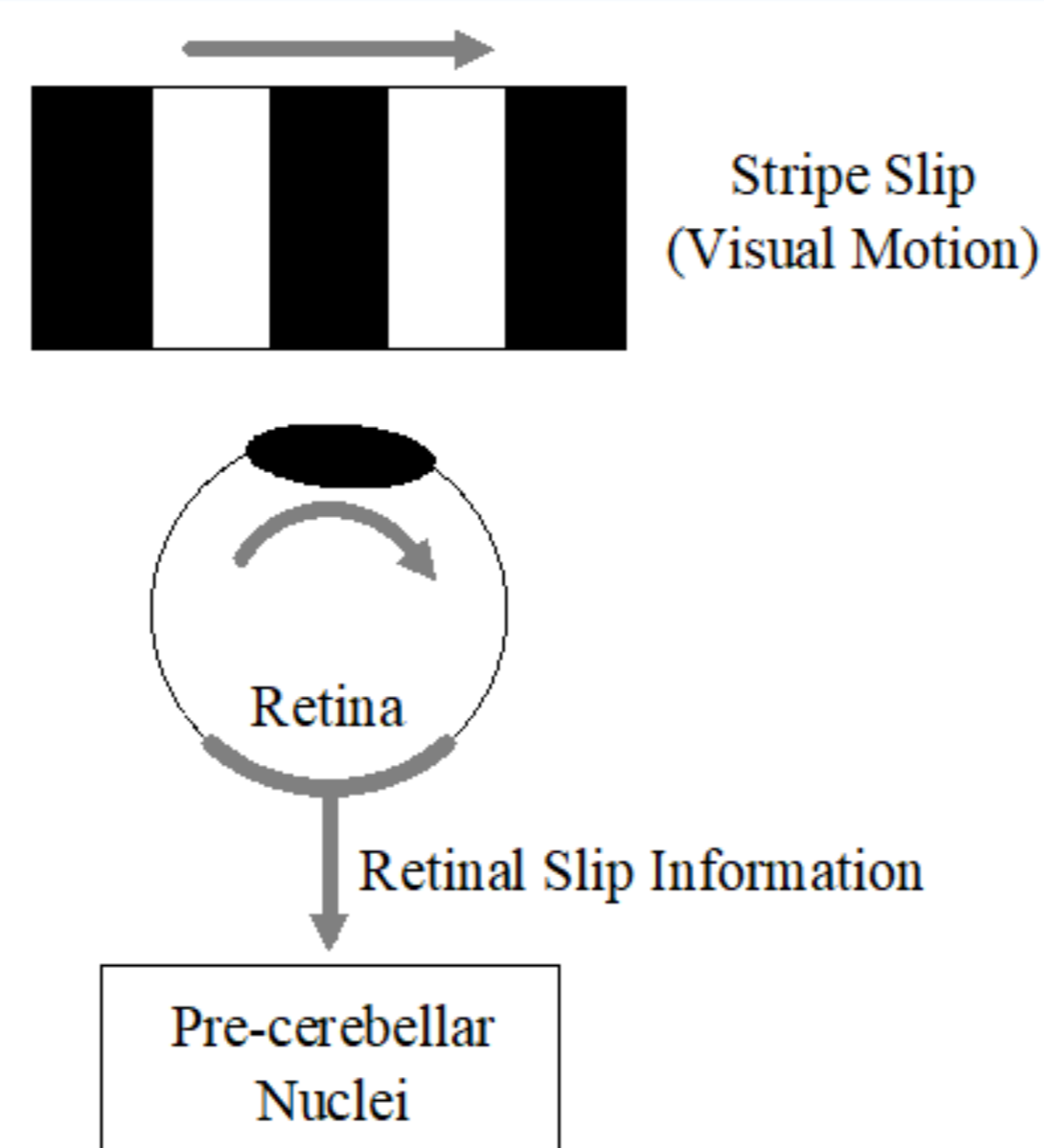

Cerebellar Ring Network for The OKR

Cerebellar Network for OKR

- Granular Layer: Input layer
 - Excitatory granule (GR) cells & Inhibitory Golgi (GO) cells
- Purkinje-Molecular Layer: Output Layer
 - Inhibitory Purkinje cells (PCs) & basket cells (BCs)
- Context signal for the post-eye-movement via mossy fiber (MF)

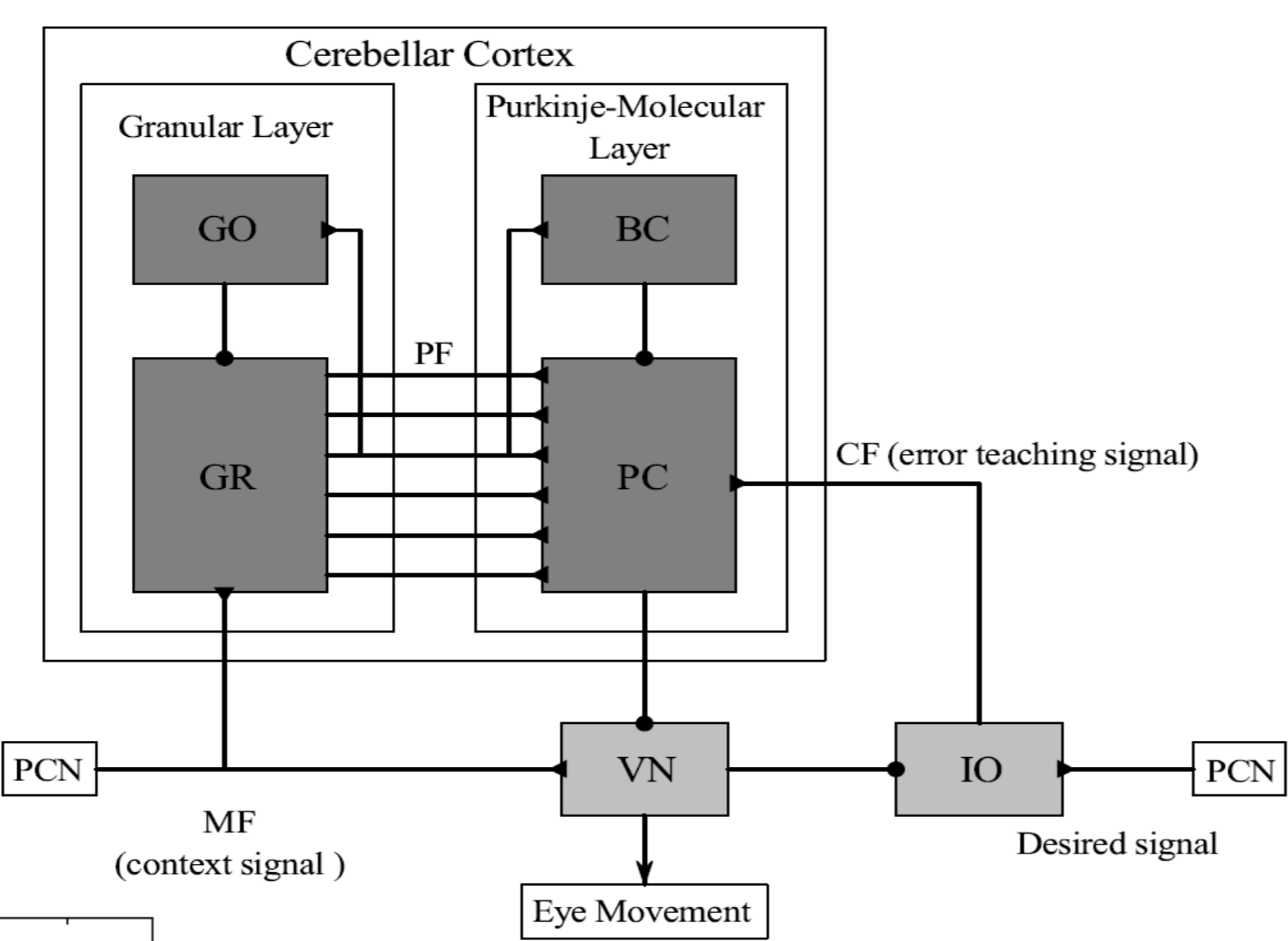

- Desired (eye-movement) Signal (DS) into inferior olive (IO)

Granular-Layer Ring Network

$N_c (= 2^{10})$ GR clusters
 $N_{GR} (= 50)$ GR cells in each GR cluster
 N_c GO cells
 Each GR cluster bounded by two glomeruli (GL):
 Each GL: One MF & ~ 5 GO cells ($p_c = 0.06$)

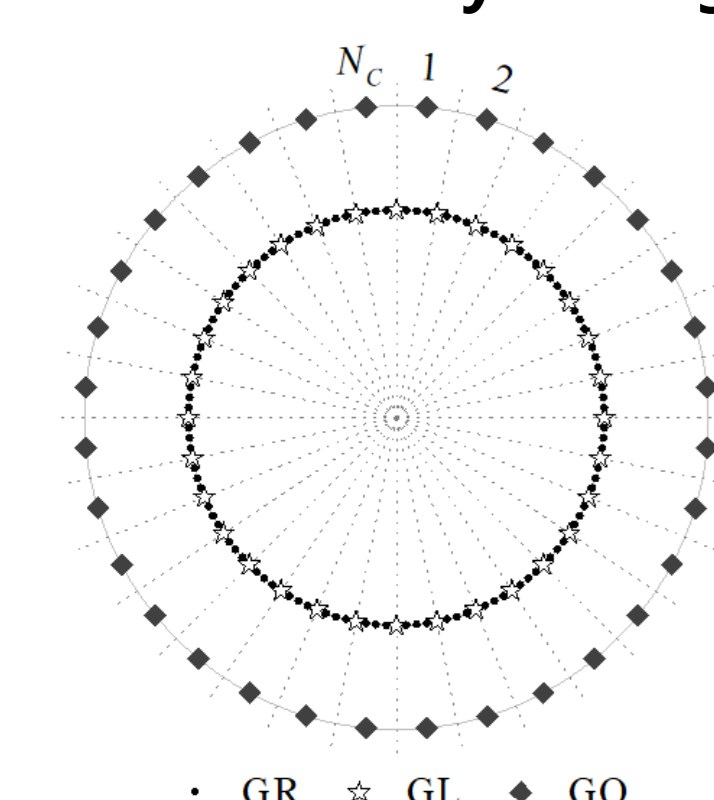

Purkinje-Molecular-Layer Ring Network

$N_{PC} (= 16)$ PCs & BCs

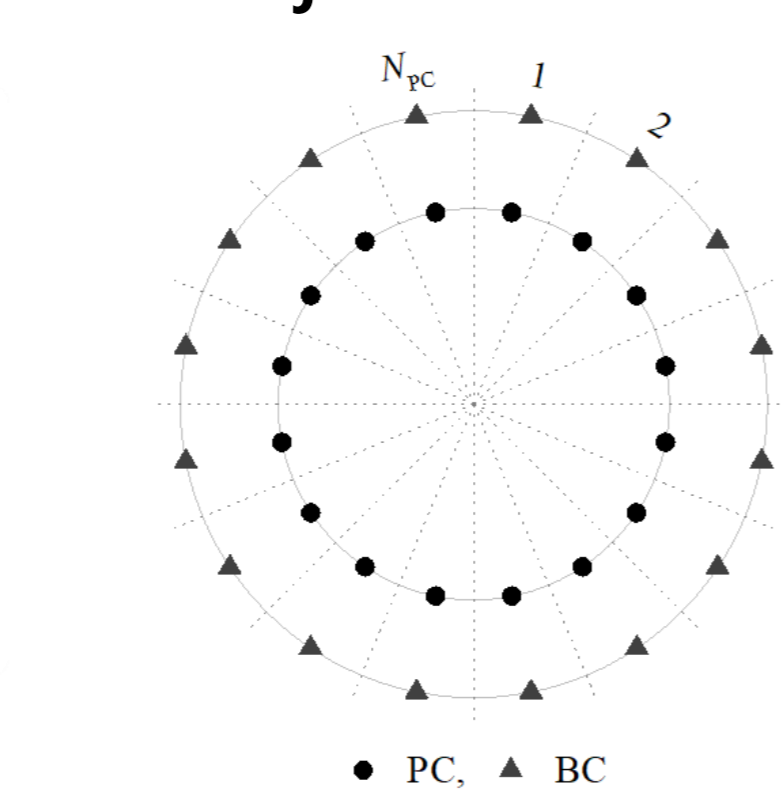

Refined Rule for Synaptic Plasticity at Parallel Fiber(PF)-PC Synapse

$$J_{ij}^{(PC,PF)}(t) \rightarrow J_{ij}^{(PC,PF)}(t) + \Delta LTD_{ij}^{(1)} + \Delta LTD_{ij}^{(2)} + \Delta LTP_{ij}$$

- Synaptic modification [long-term depression (LTD) or potentiation (LTP)] depending on the relative time difference between CF (climbing fiber) & PF activation times

$\Delta LTD_{ij}^{(1)}$: Major LTD in the case that the CF signal is associated with earlier PF signals

$\Delta LTD_{ij}^{(2)}$: Minor LTD in the case that the CF signal is related to later PF signals

ΔLTP_{ij} : LTP in the presence of PF signals alone without association with the CF signal

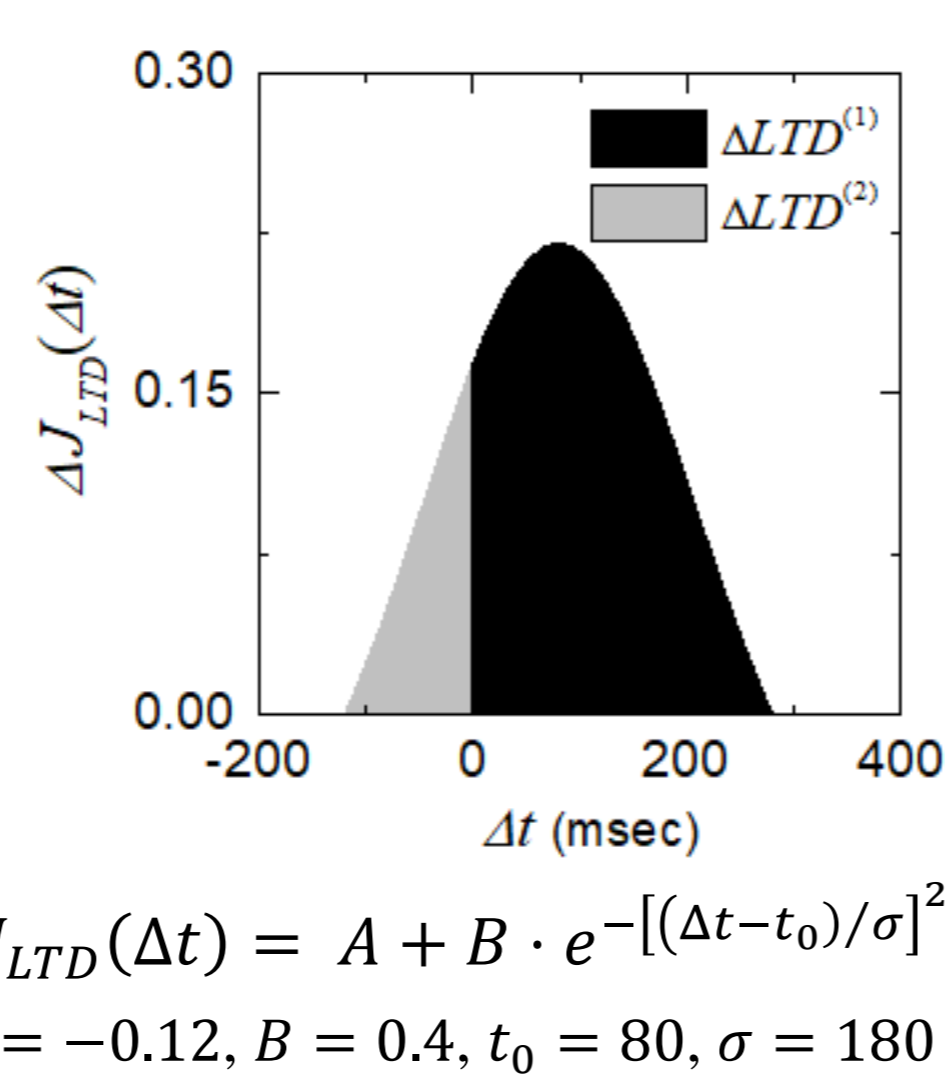

Diverse Spiking Patterns of The GR Clusters

Optimal case: $p_c^* = 0.06$

Firing Activity in The Whole GR Cells

- Raster plot of spikes of 10^3 randomly chosen GR cells:
 - Initial & final stages of the cycle: Sparse and uniform firing
 - Middle stage: Dense and non-uniform firing
- Instantaneous whole-population spike rate $R_{GR}(t)$: Basically in proportion to the MFs.

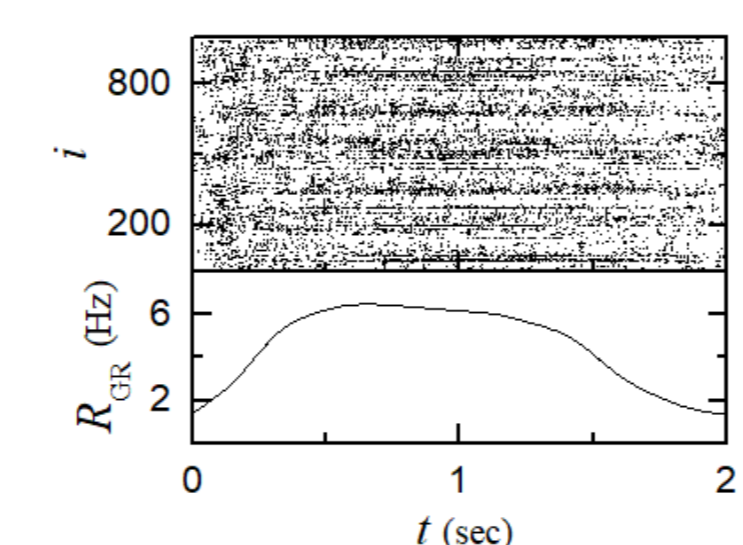

Diverse Spiking Patterns in GR clusters

- $R_{GR}^{(i)}(t)$: Instantaneous cluster spike rate in the i th GR cluster

- Diverse spiking patterns $R_{GR}^{(i)}(t)$; in-phase, anti-phase, or complex out-of-phase with respect to their population averaged firing activity $R_{GR}(t)$.

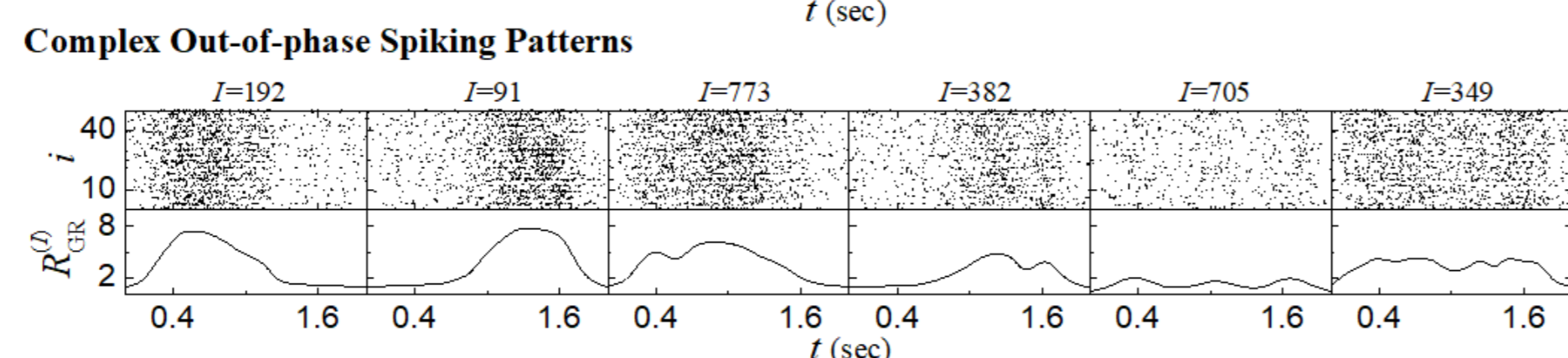
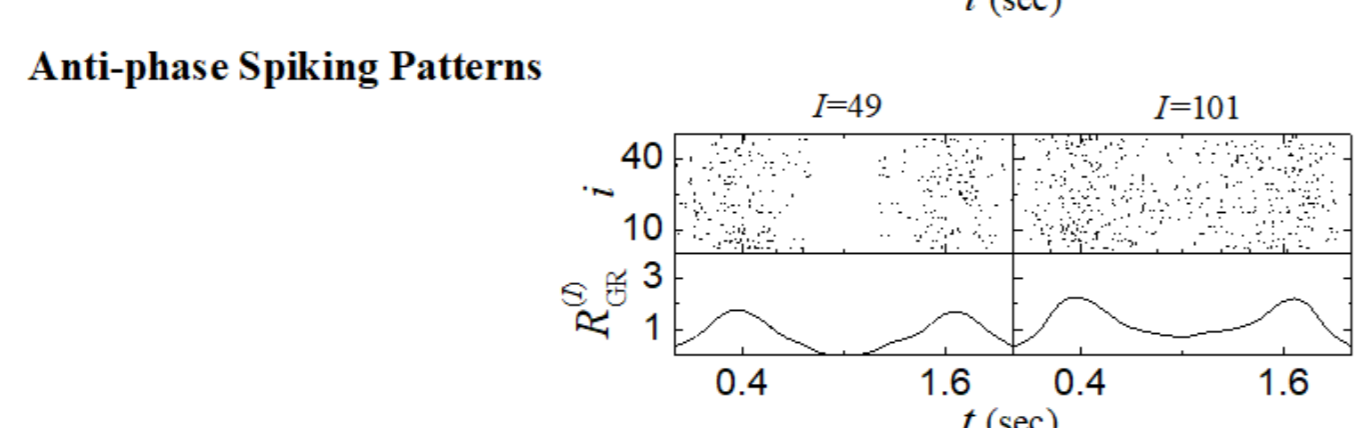
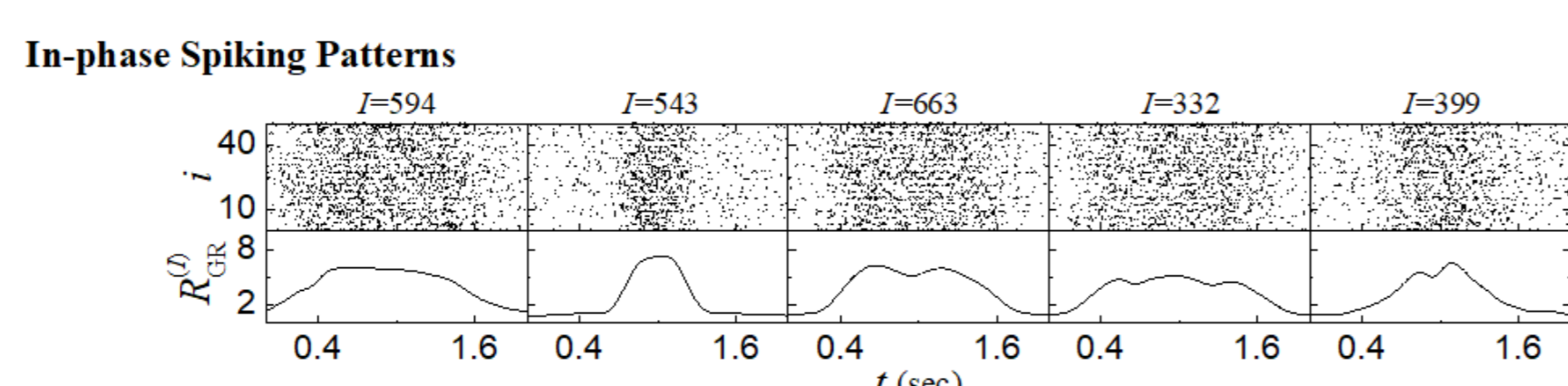

Characterization of Diverse Spiking Patterns

- Conjunction index $c^{(i)}$: Cross-correlation between $R_{GR}^{(i)}(t)$ and $R_{GR}(t)$ at the zero-time lag

- Diversity Degree \mathcal{D} : Relative standard deviation of $\{c^{(i)}\}$
 $\mathcal{D} = 1.613$

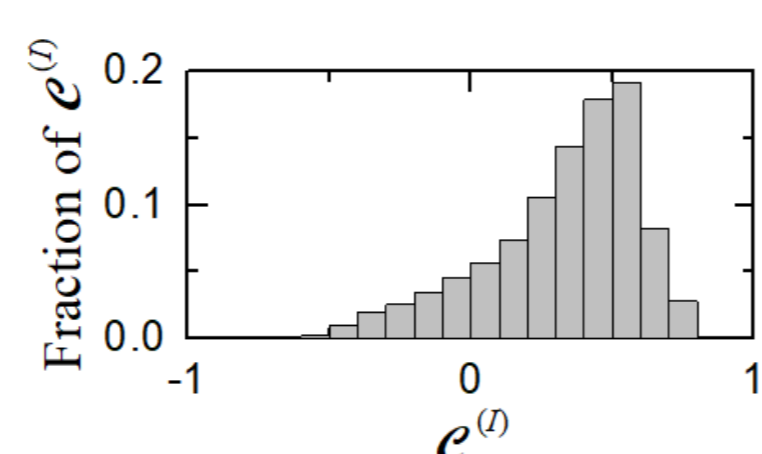

Change in PF-PC Synaptic Weights during Learning

Distribution of Normalized Active PF-PC Synapses

In-phase PF signals: Strongly depressed (i.e., strong LTD) by the in-phase CF signals
 Out-of-phase PF signals: Weakly depressed (i.e., weak LTD) due to the phase difference between the PF and the CF signals.

Middle stage of cycle: Strong LTD via dominant contributions of in-phase PF spikes
 Initial & final stages: Weak LTD via contributions of both in- & out-of-phase PF spikes

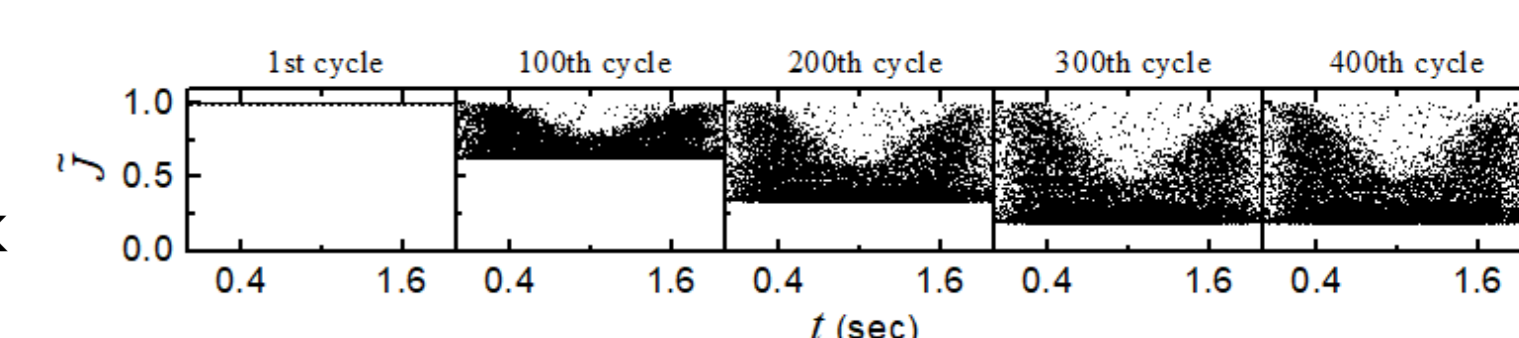

Bin-averaged Synaptic Weights $\langle \bar{J} \rangle$ of Active PF

Well-shaped curve
 With the cycle, the well curve goes down, increase in modulation $[(\text{maximum} - \text{minimum})/2]$, and saturation at about the 300th cycle.

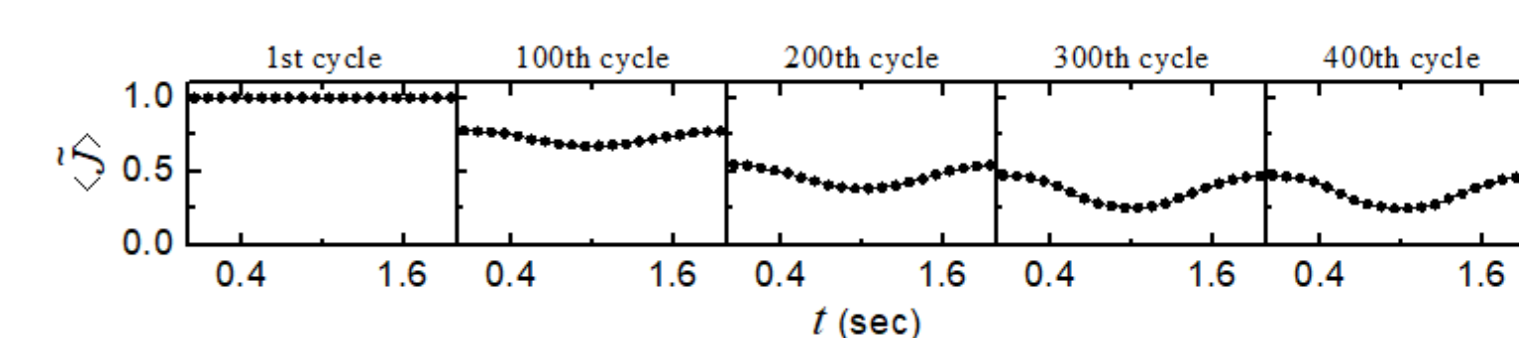

Change in Firing Activity of PCs during Learning

With Raster Plots of Spikes

With the cycle, more sparse at the middle part due to strong LTD

Population Spike Rates $\langle R_{PC}(t) \rangle_r$ of PCs

- Well-shaped curve with big modulation due to effective depression of PF-PC synapse

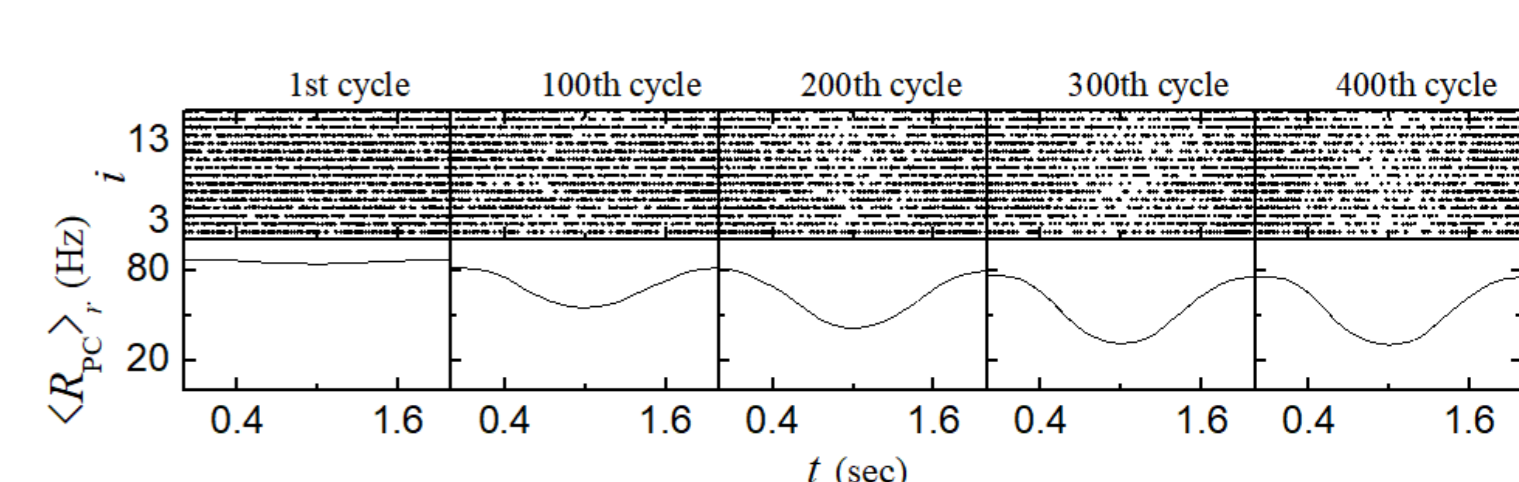

Change in VN's Firing Activity and Learning Gain Degree

Firing Activity of VN during Learning

- VN: Evokes the OKR eye-movement
 - Effective inhibitory coordination from PCs on the VN
- Raster plots: with the cycle, more dense at the middle stage in contrast to the PC
- Firing Activity of VN neuron: Bell-shaped curve with a maximum at the middle stage. With the cycle, the bell curve goes up, increase in modulation, and saturation at about the 300th cycle.

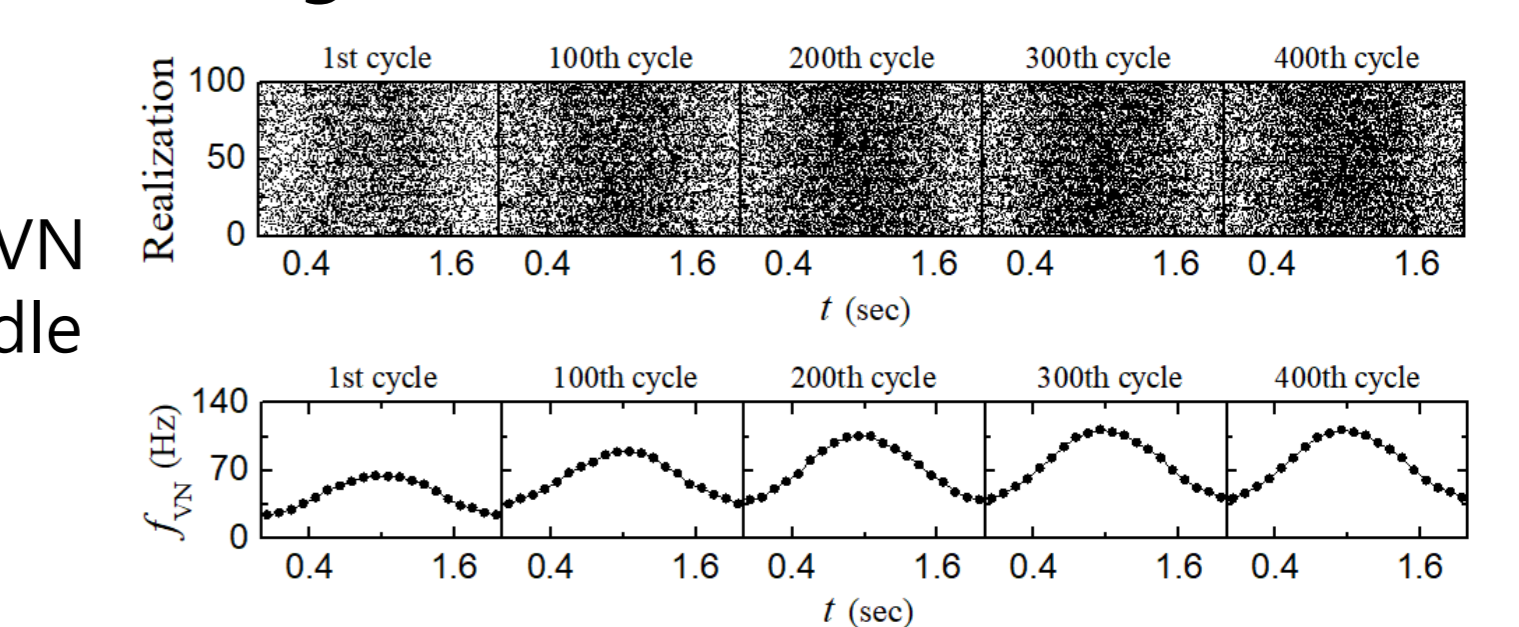

Learning Gain Degree \mathcal{L}_g

- \mathcal{L}_g : the modulation gain ratio (i.e., normalized modulation divided by that at the 1st cycle)
- Increase with the learning cycle and saturated at about the 300th cycle.
- The saturated learning gain degree $\mathcal{L}_g^* (\sim 1.608)$.

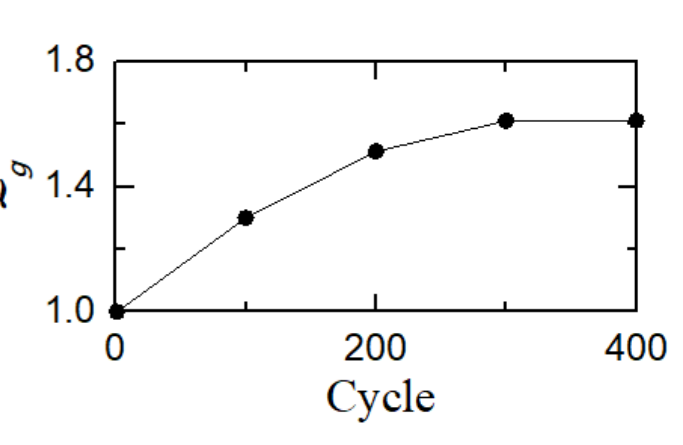

Learning Progress in The IO System

Learning Progress

- Two inputs into IO: excitatory desired signal for a desired eye-movement and inhibitory signal from the VN neuron (denoting a realized eye-movement)
- With the cycle, increase in inhibitory input from the VN neuron, and convergence to the constant excitatory input through the IO desired signal.

- Learning progress degree $\mathcal{L}_p = \frac{I_{GABA}^{(IO,VN)}}{I_{AMPA}^{(IO,DS)}}$

Increase with learning cycle and saturated at 1 at about the 300th cycle.

Firing Activity of IO neuron during Learning

- Raster plots: With the cycle, spikes at the middle stage becomes sparse due to increased inhibitory input from VN
- Firing Activity of IO neuron: Bell-shaped curve with a maximum at the middle stage. With the cycle, decrease in the amplitude, and saturated at about the 300th cycle.

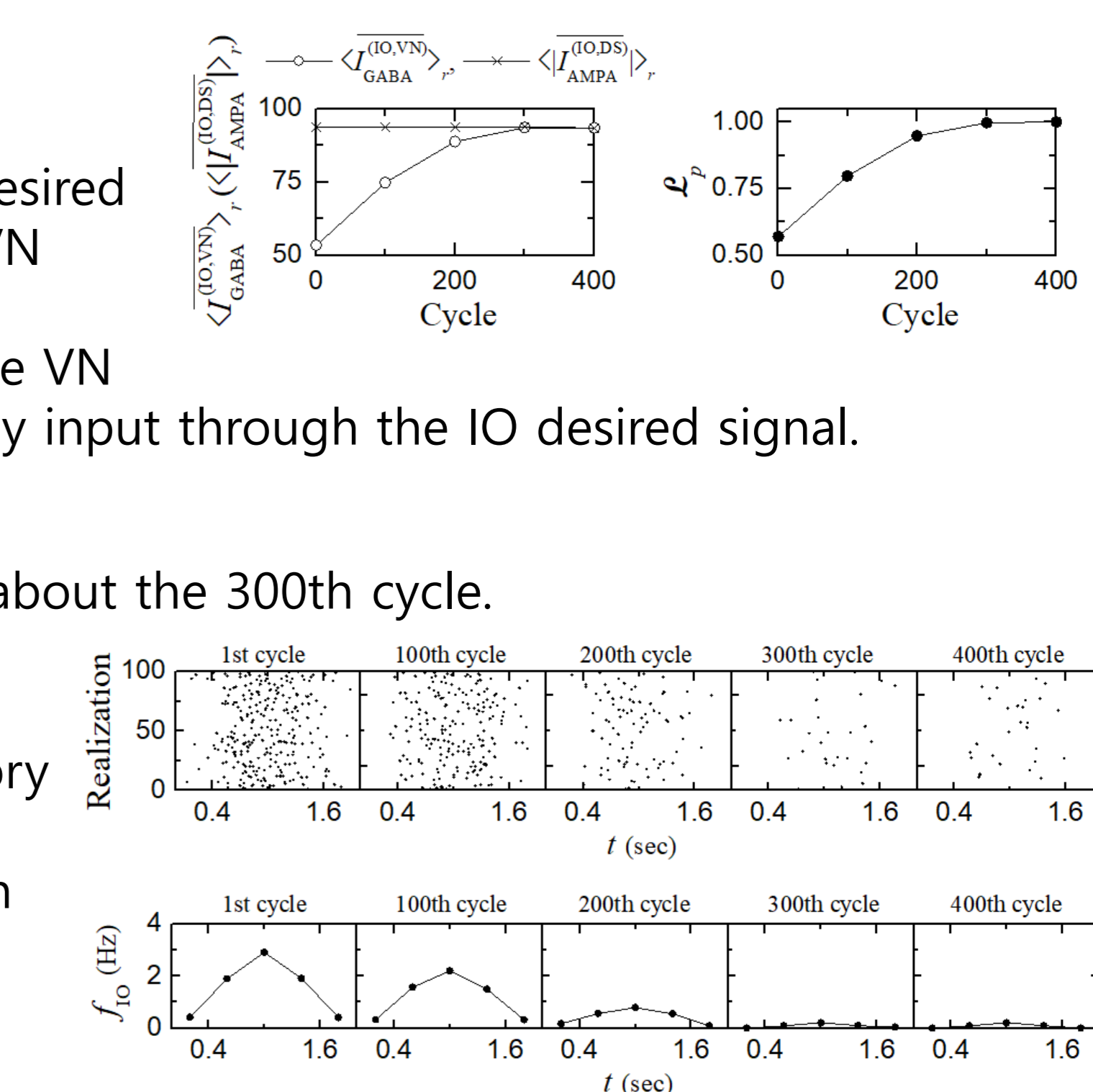

Relation between Diverse Recoding and Learning Gain Degree

Diversity Degree (\mathcal{D}) & Saturated Learning Gain Degree (\mathcal{L}_g^*)

Bell-shaped curves with maximum at the same optimal value of $p_c^* = 0.06$

Strong Correlation between \mathcal{D} and \mathcal{L}_g^*

The more diverse in recoding of granule cells \rightarrow The more effective in motor learning for the OKR adaptation

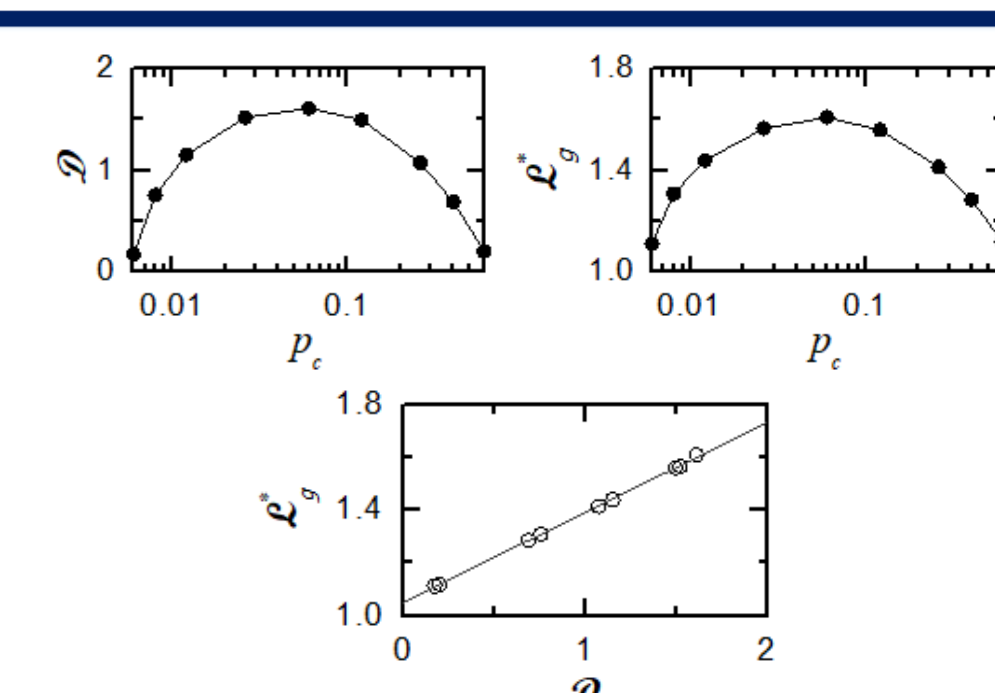

Summary

Diverse Recoding in The GR clusters

Appearance of diverse in- and out-of-phase spiking patterns, due to inhibitory coordination of GO cells. Characterized in terms of conjunction index and diversity degree

Effect of Diverse Recoding on The OKR

Effective depression at the PF-PC synapses
 In-phase PF signals: Strong LTD by the in-phase CF signals
 Out-of-phase PF signals: Weak LTD
 \rightarrow Big modulation in firing of PCs & VN Neuron

Relation between Diverse Recoding and Learning Gain Degree

Strong Correlation between Diversity Degree \mathcal{D} and Saturated Learning Gain Degree \mathcal{L}_g^*
 \rightarrow The more diverse in recoding of granule cells, the more effective in motor learning for the OKR adaptation.